



Section 5.0

## Exhibit F – General Design Drawings

---

### 5.0 General Design Drawings

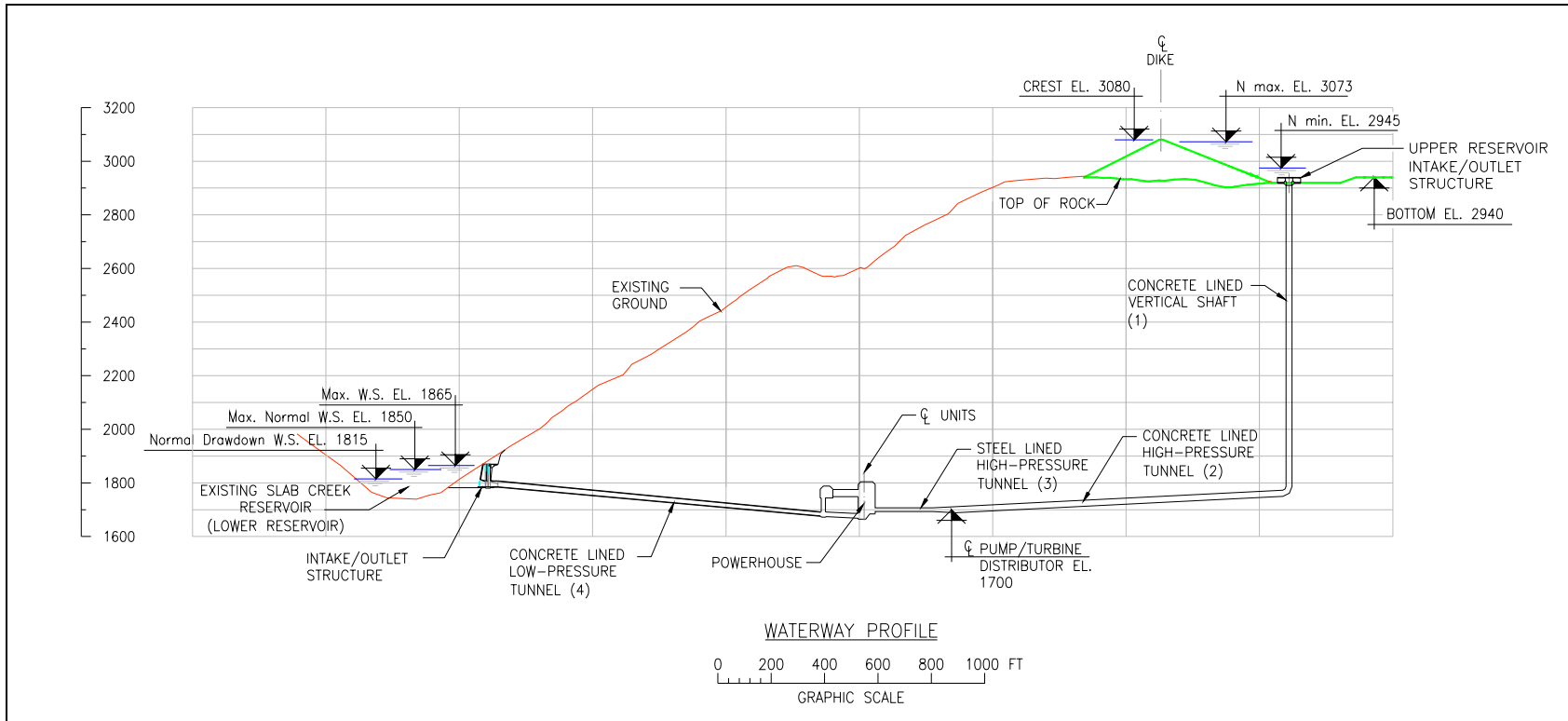

Figure 5.1 Cross-Section of Iowa Hill Pumped Storage Development

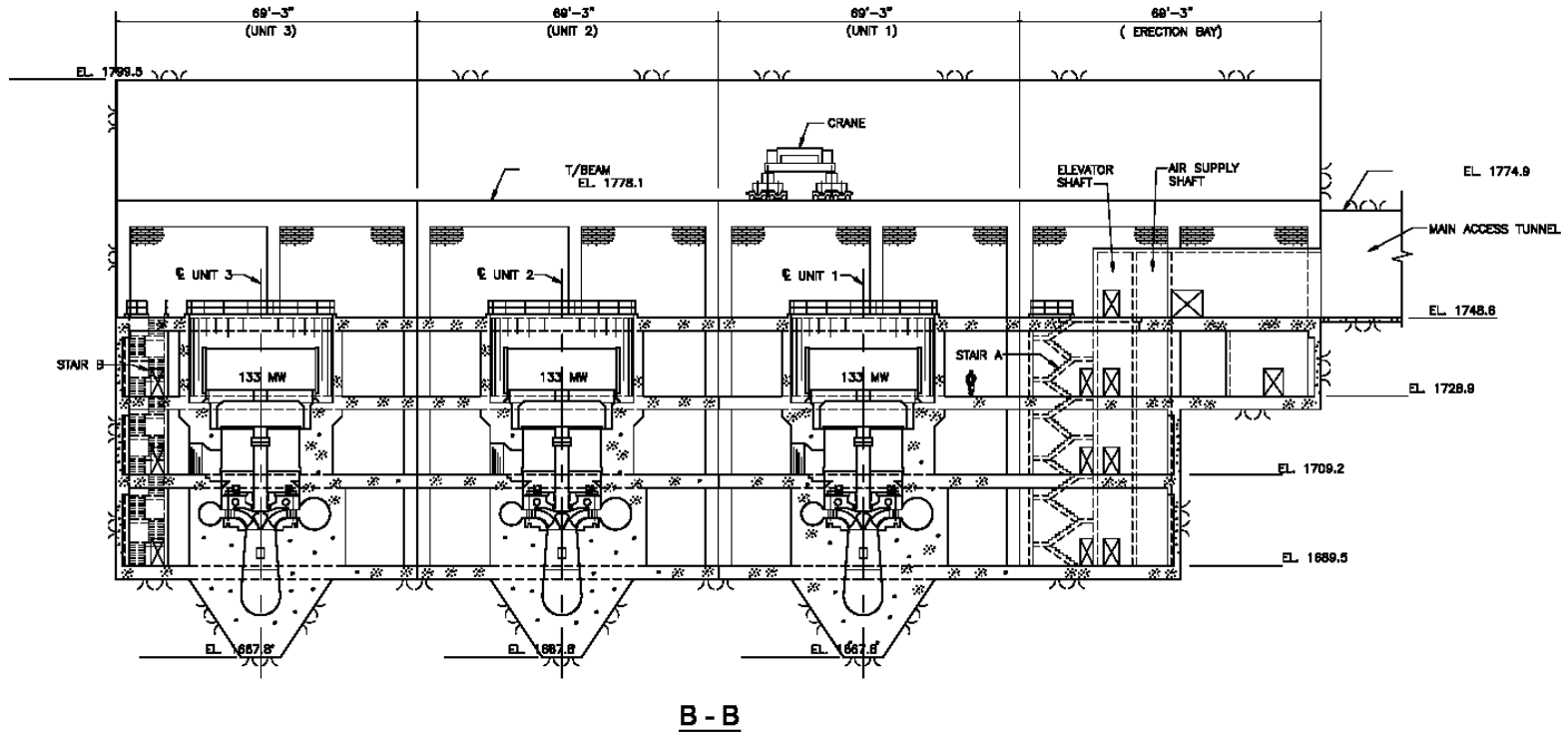

Figure 5.2-1 Powerhouse Cross-Section View 1

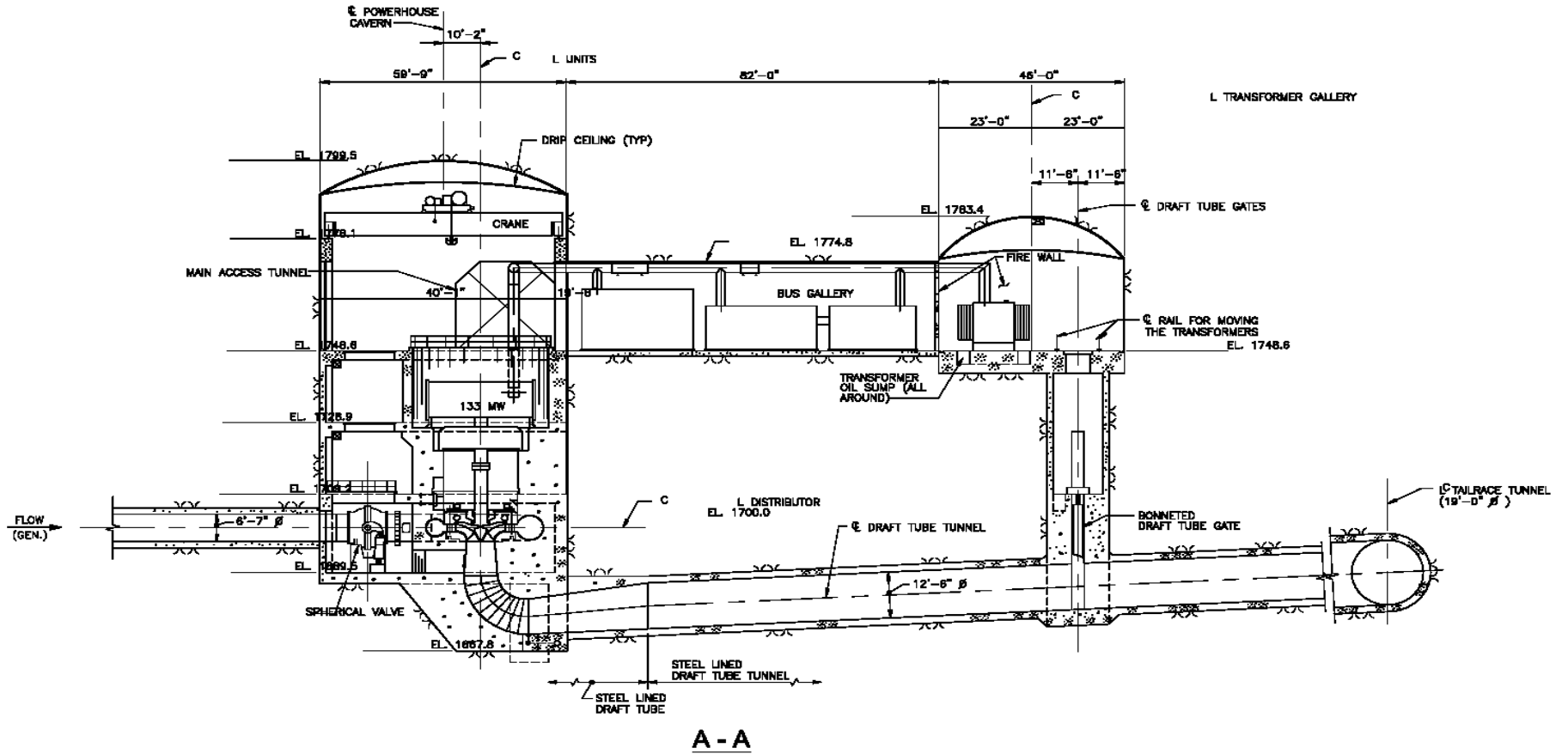

Figure 5.2-2 Powerhouse Cross-Section View 2

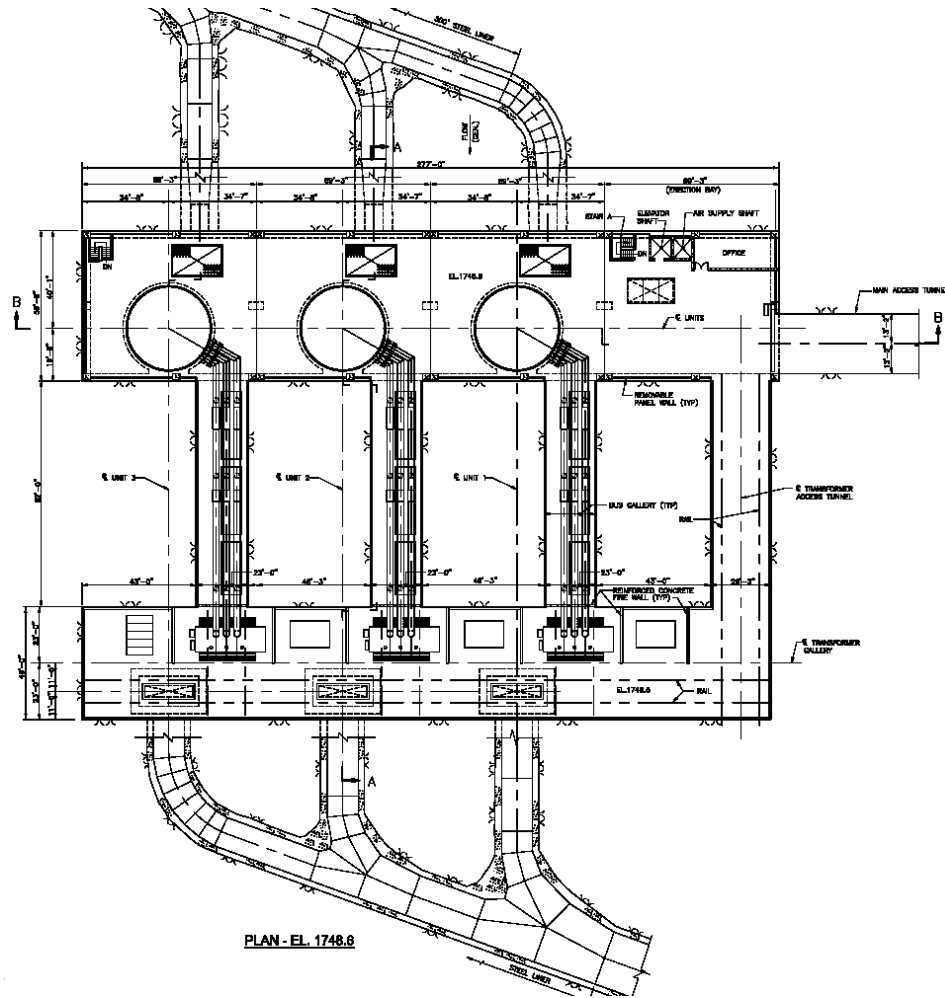
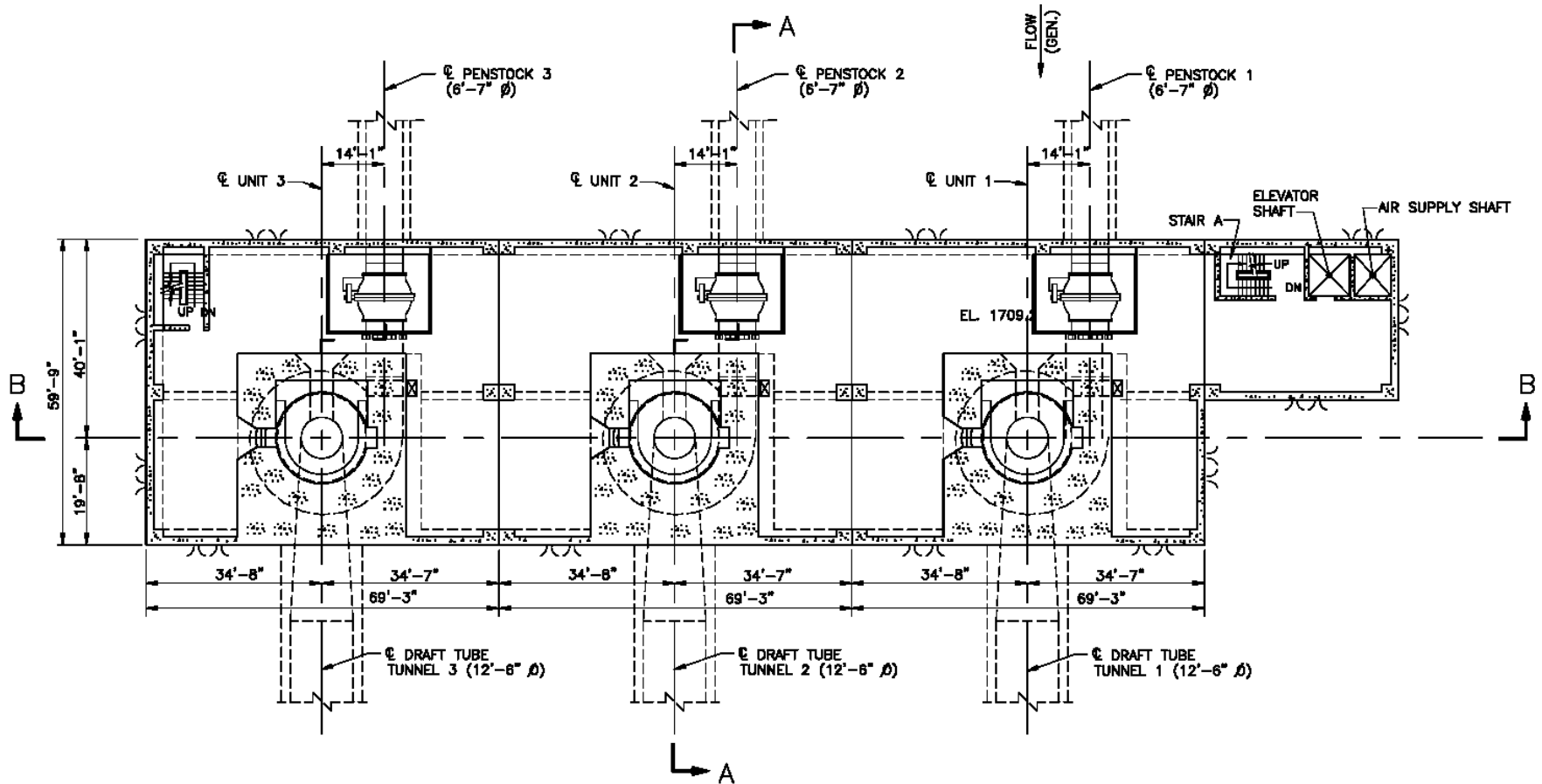

Figure 5.2-3 Powerhouse Plan View at Elevation 1748.8 ft.





**PLAN - EL. 1709.2**

**Figure 5.2-5 Powerhouse Plan View at Elevation 1709.2 ft.**